

## Router Repair Of Soundboard Cracks

### *Using the Spurlock Specialty Tools Carbide Router Bit and Router Base*

© 1998 Bill Spurlock



When repairing a soundboard we would like to restore the bridge-soundboard-rib-rim assembly to a sound structural unit to make it as much like new as possible. All glue joints between bridge, board, rim and ribs should be secure. In repairing cracks we would like to retain or even enhance the crown, and end up with shims that are under compression along with the rest of the board. As in any good wood joint, the shims should fit the soundboard perfectly and without voids to ensure long term reliability. The cosmetics of crack repair are also important, especially in grands.

Carving out cracks by hand to accept shims is made difficult because cracks are never perfectly straight. Instead they wander and lean, sometimes jumping over to the next grain and continuing. Often multiple cracks are found close together, requiring that a very wide shim (or narrow panel) of new wood be installed. This makes the usual process of hand-carving using a shimming tool very difficult and time consuming, often leaving a less-than-perfect shim fit. In addition, the hand carving process actually crushes wood along the sides of the groove, which is then subject to failure again.

By using a router, curved or branched cracks of any width can be turned into perfectly machined grooves, ready to accept accurate-fitting shims. All damaged wood along the borders of cracks is removed. With this method the repair is faster, the quality better, and the structural integrity of the repair is optimum. The following is a step-by-step procedure for repairing soundboard cracks using our special routing system.

## Drying the Board

(Note: All repairs should be completed with the old finish still on the board, then the board can be scraped, sanded and finished.) Prior to doing any repairs the soundboard should be dried down to reveal the full extent of the cracking and loose glue joints. *The board should be dried just slightly further than the conditions that caused the present damage.* This point is indicated when the existing cracks extend longer and become noticeably wider. Use a magnifying glass to look at the ends of the cracks; if you see clean white wood this indicates new cracking and proves that the board is drier than it has been before.

I like to hang Damp-Chaser rods totaling about 100 watts or more under the piano and drape the case with blankets covering the top of the board and hanging down to the floor. The top surface of the board should feel noticeably warm, but not hot, during drying. The spruce shim stock should also be dried at the same time by laying it on top of the board and under the blankets. Be careful of fire hazard! Electric space heaters and heat lamps will build up extreme heat in the enclosed space under the piano and can cause a fire.

*Avoid over-drying the board.* This can shrink the board excessively and create needless further damage to the board and its glue joints. Remember that you are only trying to identify the extent of all current problems and not to create more damage. Once the board is dried sufficiently, reduce the heat by about two thirds and maintain it there until all repairs are done and the board is finished.

## Repairing Loose Ribs and Glue Joints

After drying the board, inspect it thoroughly for any loose glue joints. A thin artist's pallet knife is useful for probing between ribs and board, and around the rim. To help maintain the original shape and structure of the board, the crown should be forced up with wedges prior to any glue joint repairs. Use wooden wedges between the beams and ribs, padding all surfaces with old backrail cloth to prevent scarring. Use discretion; like the bottom of an oil can, the board will deflect a small amount easily and then become very resistant. Stop well before you drive the board loose from the rim or break a rib.

I prefer to repair these joints with hide glue, since in most cases that is the glue that was used originally. Since we cannot open up the joints to clean out the old glue residue, it is better to use a glue that is compatible with, and will re-activate, any remaining old glue in the joint. Regular hot hide glue will not have an adequate working time here, so you will need to slow down its gel-time by adding urea (a fertilizer, sometimes found at gardening stores) in the proportions of 2 teaspoons urea per tablespoon of dry glue granules or more as needed. Alternatively, just use Franklin's Liquid Hide Glue, sold in most hardware stores (always check the expiration date and don't use if expired).

Loose soundboard-to-rim joints can be clamped from above using a bar clamp and block of wood down to the soundboard. Loose ribs can be clamped using the simple tuning pin clamp blocks shown at right:

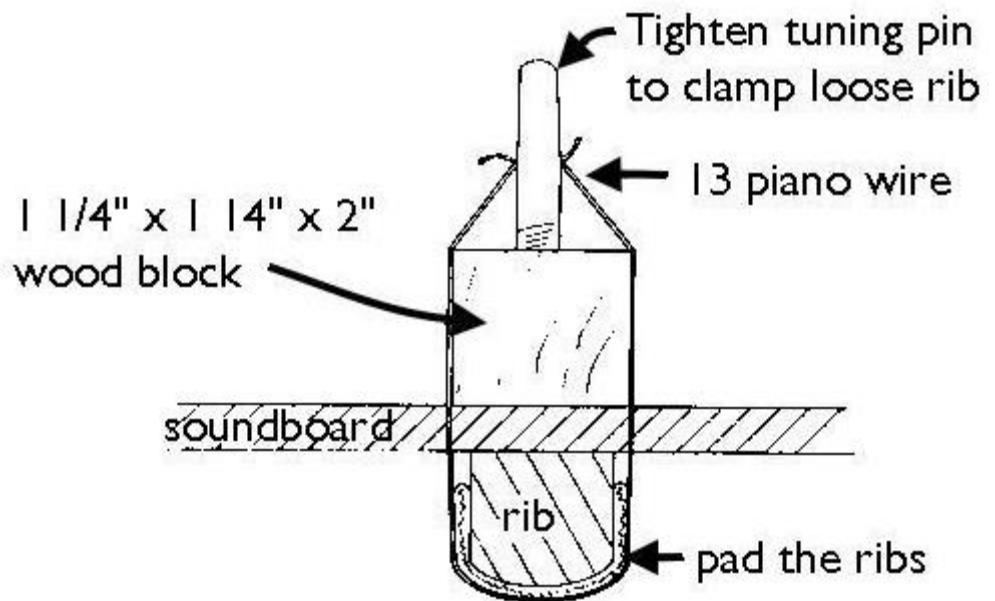

## Routing Out the Soundboard Cracks

With board and shim stock dried and glue joints secured, you are ready to begin routing. While a conventional router will work for straight, narrow cracks in open areas of the soundboard, it will not be able to get close to bridges or case parts. In addition, cutting wider grooves with a conventional router requires either remounting the fence or shimming between the router and fence between cuts. In comparison, our compact router base and versatile fence system fits into most areas of the soundboard, provides easy control, and allows routing cuts up to 6 1/2" wide from a single fence location.

The ideal power source for our router base is an air die grinder, available from us or wherever air tools are sold. These run the same speed as electric routers (around 20,000 rpm), and require 90 psi air pressure. A 1 1/2 hp or larger air compressor will do, with 10 gallon or larger storage tank. Though most die grinders consume about 4 - 6 cfm, a somewhat lower compressor output is OK since tool use during routing is intermittent, giving the compressor time to catch up during successive cuts.

For shops without compressed air, the router base can also be powered by an electric "Foredom" flexible shaft tool, as long as it has a 1/4" capacity collet in the hand piece. However, these turn at somewhat slower speed than the air tools and are much more expensive.

The router base uses 1" x 1" x 1/8" angle aluminum (available from most hardware stores) as fence material; slots in the base engage the angle metal so the router rides along like a monorail, supported by the fence and by nylon screw "feet." This system provides a positive guide system for the router, virtually eliminating the chance for the bit to veer off of its path. *Note: Take the router base or a micrometer when shopping for the angle aluminum, and make sure to select a piece that is no thicker than .124". Some batches are thicker, and will not fit into the base slots. A looser fit in the slots is fine.*

### The air router can be used in two modes:

- **The air router can run *cross-wise* to the aluminum fence** - This is the most useful mode because it allows you to widen your initial cut to clean up wandering or multiple cracks (by adjusting the sliding grinder mounting bracket) *without* re-mounting the fence. Since you don't have to move the fence to widen the cut, you can mount it to the board with double-stick foam tape, which is more secure and simpler than using clamps. When riding cross-wise on the fence, the router can cut a continuous slot from within about 3/4" of the rim all the way off of the belly of the piano.

To replace a wide strip of damaged soundboard, you can make your initial groove, then switch the router base to its center or rear fence slot to make a second cut up to 6 1/2" away from the first. The piece of board between the two grooves can then be removed and a new section installed.

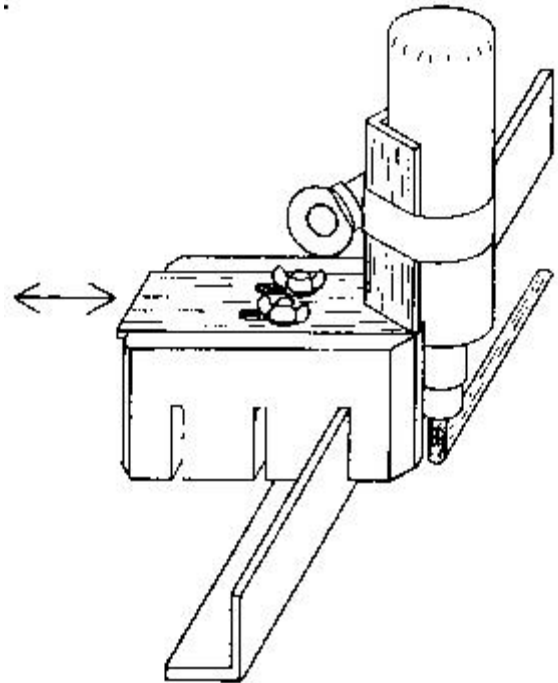

- **The air router can also ride *lengthwise* along the fence** - In this mode the path occupied by the router and fence is only 2 5/8" wide, allowing routing between a bass bridge and the rim or between bass and tenor bridges in many pianos. Some width adjustment is still possible in this mode by shimming between the grinder body and bracket. Continuous rim-to-rim cuts are not possible without stopping to turn the router around at one end of the cut, however.

Depending upon the location of the crack on the board, various fence set-ups can be used as necessary to work around bridges, etc. See examples on the following pages.

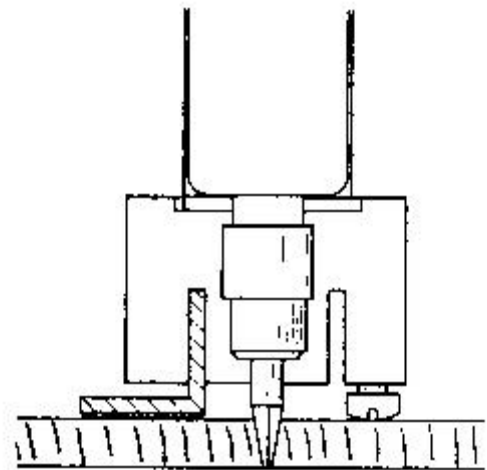

## Important Factors During Routing

● **Determine the length to rout** - Prior to routing, you should inspect the board closely and mark where the cracks appear to end. Sometimes the board will be under considerable tension from drying so that right after routing, the crack will suddenly spread beyond where your routing stopped. To avoid this, it is wise to always rout past the end of the crack to the center of the next rib. The rib will then hold the board together until the new shim is installed.

● **Mount your fence securely** - A fence can be either clamped to the board or stuck down with double-stick foam mounting tape. A short (less than 15") fence can sometimes be secured by clamping at each end. At the rim end, use a wood block slightly taller than the rim, and a bar clamp down to the lower edge of the rim. At the belly (damper guide rail area), you can C-clamp the fence to the belly rail, or to a block that has been temporarily screwed to the belly. *Longer fences need to be secured every foot or so along their length.* Use 2" pieces of 1" wide mounting tape centered every 10". The tape is faster and easier to use than clamps, and holds the fence very securely. Use the double-stick mounting tape made of white foam material that's about 1/16" thick. I carry 3M's Scotch Mounting Tape, which is also available at hardware and stationary stores.

*The board should be as flat as possible during routing, so make sure there are no wedges underneath.* Test for the correct location of the fence in relation to the crack by adjusting the router's sliding bracket approximately to the center of its travel, lowering the bit to just above the board, and sliding the router base along the fence. Look for the bit to be centered over the crack on average. Mark the desired fence location on the board. Clean dust from the board, apply your tape pieces to the bottom of the fence and press it firmly into place.

After routing, the fence can be removed from the board using a small pry bar. The tape will lift some of the old varnish off with it, so new pieces will have to be used each time.

● **Check for free movement of the router** - always "dry run" the tool over its path before actually cutting, making sure there are no obstacles and planning your cut. Make sure that the router slides freely against the fence, since any roughness or binding can cause chattering or an uneven cut.

*Always lubricate the old varnish surface of the soundboard with a cake of bee's wax or a bar of soap where the router feet ride, otherwise varnish will transfer to the router feet and cause sticking.* Make sure that the tilt of the base is adjusted using the screw feet so that the slot lines up vertically with the aluminum and cannot bind, as shown at right. If using the center fence slot, install two screw feet in the front holes and one in the center rear hole, so that the base cannot rock. If using the rear slot, again use two front screws; the rear of the base can just ride on the fence.

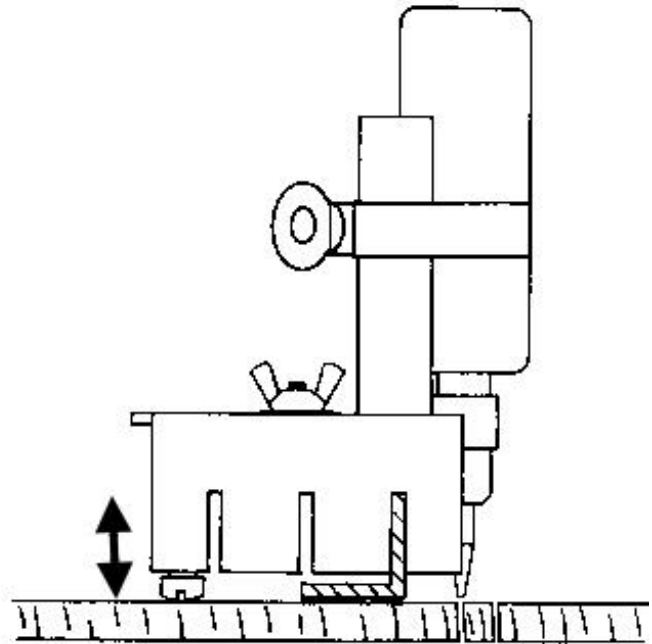

Raise or lower screw feet to adjust tilt for proper alignment of fence and base.

● **Use a lightweight overhead air line** - To eliminate any side pull on the router, use a lightweight "coil hose" air line suspended from above the piano, never a heavy rubber line leading off to the side.

● **Use proper feed direction** - always feed the router in the proper direction, taking into account the direction of rotation of the bit and the forces it will place on the router. For example, when using the base cross-wise on the fence, it should be fed such that the bit is trying to pull away from the rail, thus holding the rear foot securely in contact with the board as shown at right.

When the base is riding parallel to the fence, feed can be either direction since lifting forces are minimal.

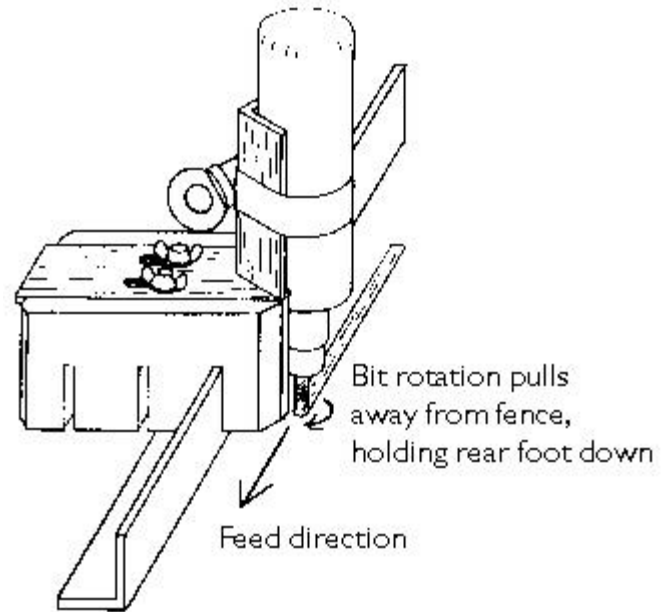

● **Make one continuous cut** - When making a cut, always move the router from one end of the crack to the other in the same direction and without stopping if possible. Once you are at the end of the cut, run the router back in the reverse direction—this will clean up the groove by taking a paper-thin shaving from the rough side of the cut.

The router will cut to within about an inch of the rim or other obstacle before the router body contacts something. The groove can be completed using a knife and chisel, or else the remainder of the crack can simply be filled with a colored epoxy.

● **Make your initial groove in several passes of increasing depth** - The smoothest cut will result if done in 3 or 4 stages. Also, since most soundboards vary in thickness, you will want to sneak up on the bottom of the board, rather than to cut to full depth only to find that the bit cut into a rib in a thinner area of the board. Where board thickness does vary, I normally compromise by allowing the bit to cut into the ribs by  $1/32$ " in the thin areas and leaving the groove not quite through the board in thicker areas; the groove can be completed with a knife where necessary.

● **Widen the groove as necessary** - Once your cut has reached full depth, look to make sure that all of the old crack has been removed. In the case of a wandering crack or several cracks close together, you may have to make extra passes to widen the groove. Leave the bit at full depth and adjust the bracket about  $1/16$ " at a time (in cross-wise mode), making successive cuts to shave one side of the groove until all of the crack is gone. Here your feed direction should be such that the bit rotates against the oncoming wood. When in parallel mode, you can insert a thin shim between the grinder body and one side of the bracket to widen the groove.

Sometimes a long crack will be cleaned up over most of its length by a narrow groove, but will have some of the crack remaining at one end only. In this case you may wish to glue a narrow shim into most of the groove, let dry, and then widen only that part of the groove that has the remaining crack. When routing the remaining groove wider, you can rout into the end of the first shim, as shown below. I like to locate this end-to-end shim joint at a rib location.

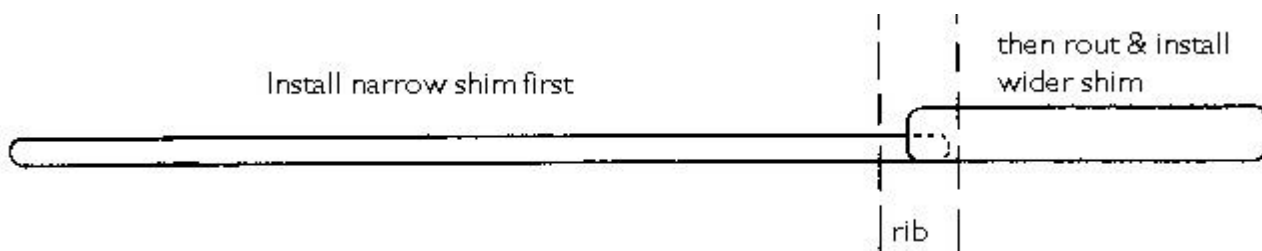

●**Install a single wide shim if necessary** - In cases where you wish to replace a strip of board more than about 1/2" wide, just make two individual grooves the required distance apart, finish the cuts all the way to the rim using a chisel, etc., and pry the bad strip of soundboard loose from the ribs. If necessary you can rout the piece loose at the rib locations using a 1/4" straight bit, plunging it into the board and cutting down to rib level.

Where there are numerous cracks running underneath the bass bridge, the best repair may be to remove the bridge so it's not in the way of routing, then re-attach it later.

●**Correcting mistakes** - Sometimes you will have a perfect groove except for one bad spot where the wood chipped or the router bumped into something and caused the bit to gouge in one spot. Instead of making the entire groove wider just to clean up a small area, it may be better to go ahead and shim the groove, then come back and repair the bad spot with a separate short shim.

## Examples of Fence Set-ups

**Cracks running from the bass side of the rim to off the front of the belly rail:** The router base should ride cross-wise on the fence and should have its front screws removed, so it rides only on the aluminum fence and the rear screw.

**Cracks that run into bridges:** To get as close as possible to a bridge, you can extend the bit in the router chuck so that the chuck will just clear the bridge at full cutting depth. This way you can cut right up until the shank of the bit contacts the bridge. With the bit extended from the chuck you will have to rout carefully with more shallow cuts than usual.

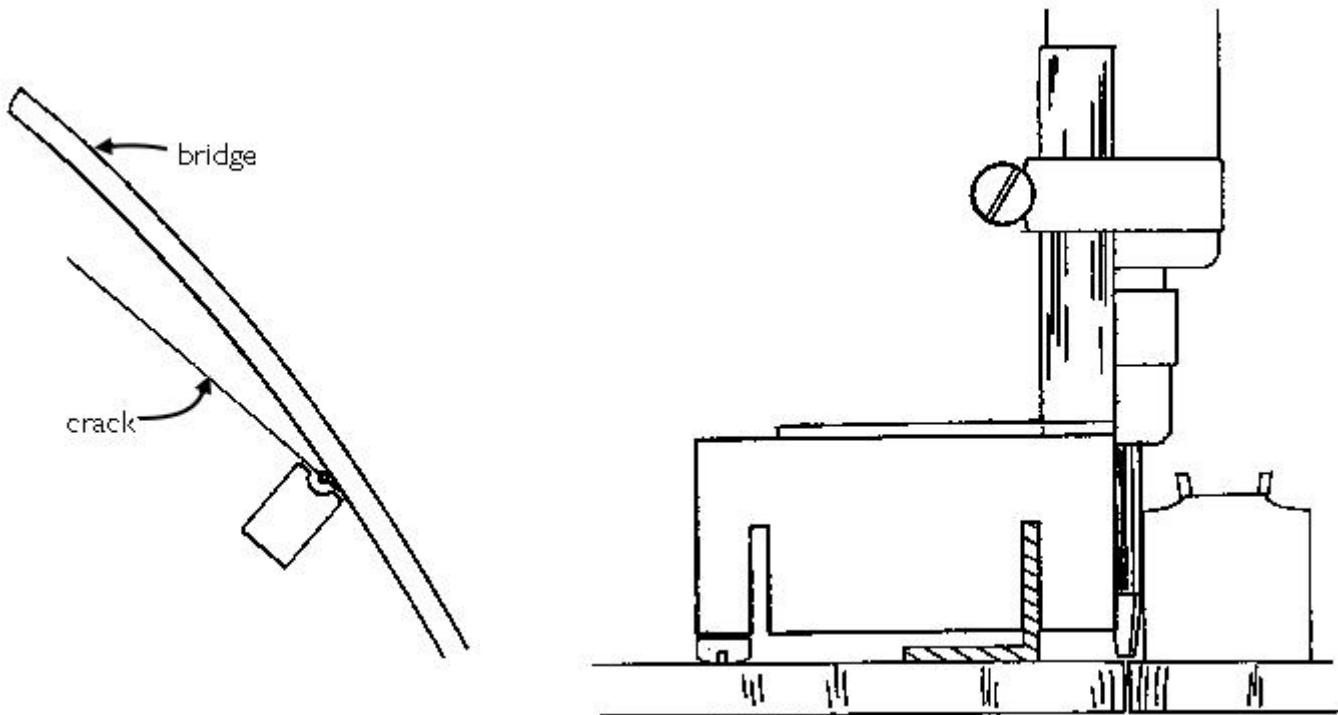

**Cracks that run up against the rim at both ends:** If the crack is not too close to the bridges, this is no problem with the router in crosswise mode. However, if clearance is tight, the most compact set-up is the router running parallel to the fence as shown below. In order to rout as close as possible to the rim at both ends, the cut will have to be made in two parts. Because the two cuts may not match up perfectly, it is best to use a two part shim. Make the first cut as usual, ending it over a rib location. Install a shim in the first cut, then rout the remainder of the crack from the rim into the end of the first shim and install the second shim. Note that whenever running parallel to the fence, the air router must have two screw feet installed on the outboard side of the router base. When the base is turned around, the screws must be switched to the other side of the base.

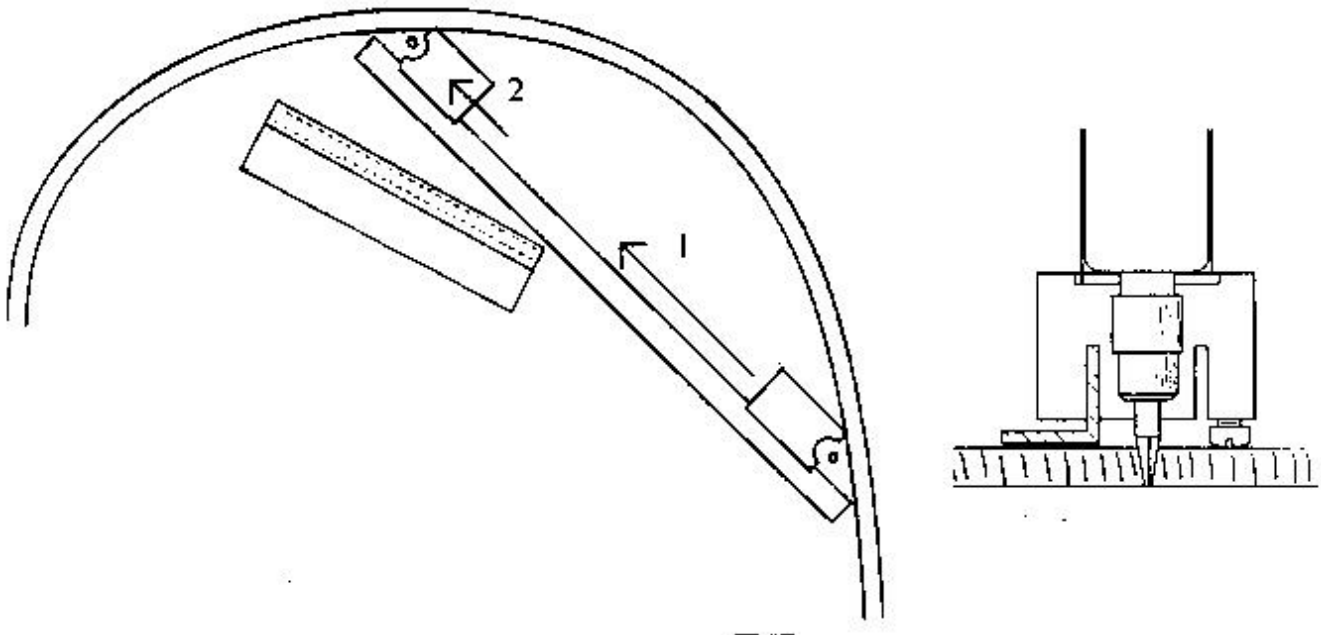

## Making Your Own Soundboard Shims

We supply quarter sawn Canadian white spruce shims custom made to fit our router bit by Andre Bolduc of Quebec. These are available in three widths. However, if you prefer to make your own or if you need wider shims, you can do so quite easily with a good table saw.

You can obtain quarter-sawn spruce from specialty woodworking stores in most larger cities, who often carry it to supply stringed instrument and aircraft builders. Alternatively, you may be able to order from one of the soundboard makers to the trade.

Quarter sawn lumber for shims should be at least 1/2" thick, since your shims need to be taller than the board thickness to allow for proper fitting. A taller shim can accommodate a range of groove widths depending upon how far it is inserted into the board.

Start by cutting one edge of the board straight and square using a table saw or jointer. The sides of the router bit are 10° from vertical. Therefore you need to tilt your table saw blade to 10°. Set your fence close to the blade and run the board through to cut a 10° angle on the straight edge of the board. Next, flip the board end-for-end, and run it through the saw again. See drawing next page. This will yield a shim cut 10° on each side. Continue flipping the board and sawing to cut as many shims as needed. Adjust the fence as needed to make shims of the desired width. A refinement is to add a facing board to

your saw fence with a matching  $10^\circ$  angle on it. This will help to hold the shim down on the table as it exits between the fence and the blade. (Note: to avoid wasting spruce, practice on scrap wood of equal thickness first.)

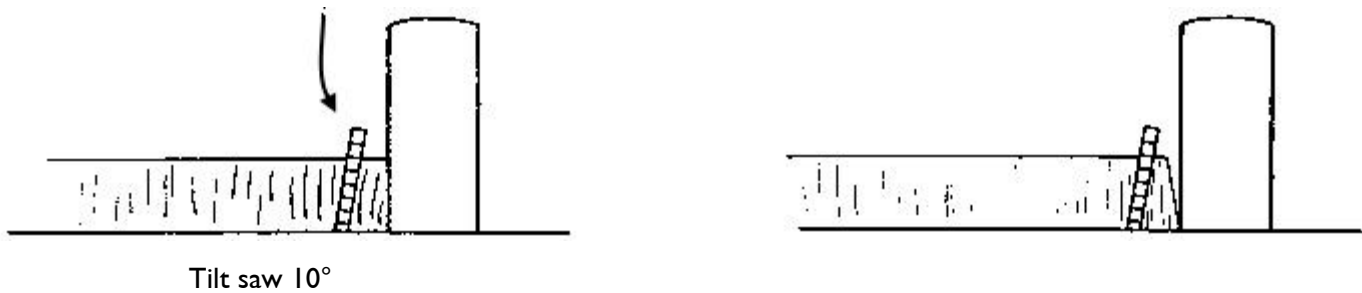

Run the board through the saw, then flip it end-for-end and run through again to make the shim. Continue flipping the board and sawing to make as many shims as needed.

## Fitting the Shims to the Board

*The board should still be in the flat state (not wedged up) during fitting.* Where your grooves end before reaching the edge of the board, you will need to round their ends to match the round shape left by the bit. The easiest way to do this is with a disc sander. Tilt the sander table  $10^\circ$  and sand the end of the shim, swinging it in an arc to make the rounded end. You can also do a very good job by hand sanding the ends of the shim using a wiping motion against a sheet of coarse sandpaper.

Next you will need to trim the shims to clear the ribs. First apply colored chalk or pencil to the exposed ribs, place the shim into the groove and tap with a mallet. Use a knife to trim the areas where the shim contacts the ribs, place it back into the groove and repeat until the ribs no longer prevent the shim from fitting tightly into the groove. You will know when this point is reached because tapping the shim into the groove will cause the shim to stick tightly. Ideally the shim should also still be contacting the ribs at this point. If both ends of the shim end within the board, you will need to continue trimming the ends as you seat the shim further into the groove.



To minimize the amount of trimming you will have to do on the bottom surface of the board, it is wise to trim the bottoms of the shims now, before gluing. This can be done quite accurately by laying the shim upside-down on the bench top with one end butted up against a stop. Using a hand plane, trim down with light cuts almost to the depth of the rib notches. Then when the shim is glued in place there will be little or

no shim protruding below the board. This is especially helpful where access to the bottom of the board is difficult due to numerous beams.

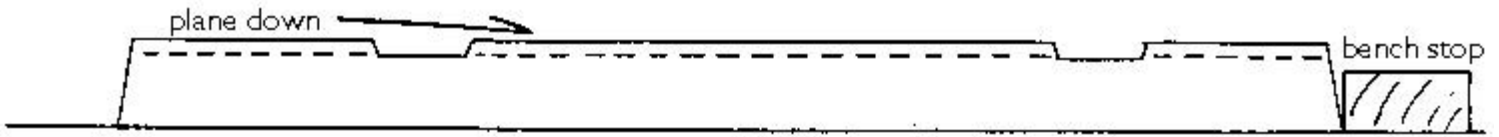

## Gluing in the Shims

I prefer Franklin's cold liquid hide glue for gluing in shims. While it leaves a slightly darker glue line than does yellow wood glue, it has a longer working time, allowing you to apply it and install the shim before it begins to thicken or swell the shim excessively. This is important when gluing in long shims. **Important: always test cold liquid hide glue on scrap wood first to make sure it sets up properly, and never use if past its expiration date.** Both cold liquid hide glue and yellow wood glue are clean to work with, congealing fast enough that the glue squeeze-out at the bottom of the shim sets up without running on through.

Epoxy is *not* a good glue for soundboard shims because it is waterproof and therefore will not expand and contract along with the rest of the board during humidity changes. This makes it incompatible with the surrounding wood and can lead to cracking adjacent to the repair. Epoxy *can* be used for finishing up the last inch or so of crack near the rim, since the board is immobilized by the inner rim at that point anyway. Epoxy must be colored however, since clear epoxy will appear as a very dark line when cured. Another problem with epoxy is its tendency to drip out the bottom of the joint, leaving voids and making a mess.

As with any gluing, it is essential to dry fit everything and test your clamping method before spreading any glue. My favorite method of clamping shims is with light weight go-bars propped against the ceiling. These make a very quick and convenient method of applying moderate pressure to as many points along the shim as needed. If your shop does not have a low ceiling, you can mount a beam about 4' above the piano using double ended pipe clamps as shown at right, and prop the go-bars against that. Have the go-bars in place, with their lower ends sitting on scrap wood alongside the groove so they can be quickly stepped onto the shim during gluing.

*Prior to gluing in a shim, wedge up the soundboard under the groove you are working on.* This will expand the groove slightly and help the glued shim seat as deeply as it did when dry.

Since the wood glue contains water, you should spread it as fast as possible and assemble the joint before the wood swells any more than necessary. Use fresh glue that is very liquid, and apply it liberally to the groove only. Press the shim into place, tap with a mallet, and install the go-bars. Then pull back the wedges under the board slightly to further clamp the shim. Leave the glue squeeze-out alone at this time. The shims only need to be clamped for about 1/2 hour.

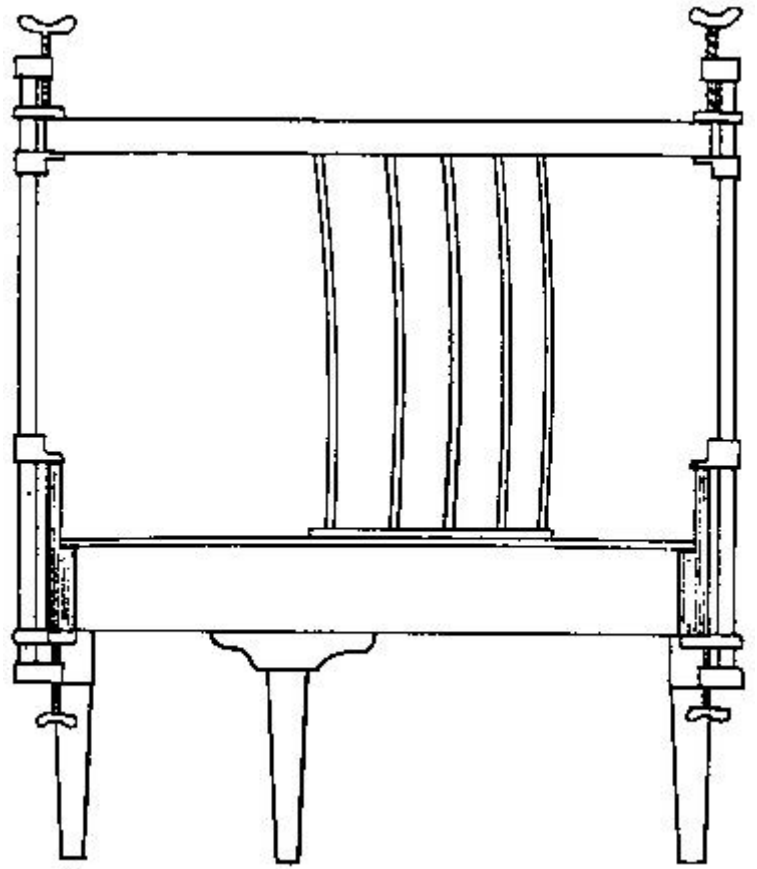

## Trimming the Shims

Before the glue has had a chance to set hard, get underneath the piano and trim off the squeeze-out and any protruding shim. I find that a very sharp chisel that is quite a bit wider than the shim will trim without scarring the surrounding varnish. In tight areas a small plane blade works well.

*The piano should be left draped with slight heat applied for at least 24 hours before trimming the tops of the shims.* This gives the moisture in the glue a chance to dissipate, so that when the shims are trimmed flush they will not shrink below the board later. Where the shims are quite high, it is best to trim them to within 1/8" of the board using a chisel or small plane. The remainder can be trimmed down almost flush using the router with a straight bit. For this operation the fence is not necessary; just install four screw feet in the base so it will straddle the shim.

## Finishing the Board

Finally, the board can be scraped and sanded. If you would like to try to darken the shims slightly to match the old board, first apply a thin coat of sealer or finish to the whole board to reveal the finished appearance of the two woods. You can then use an air brush and very dilute shading stain to lightly color the shims. Be *very* conservative, applying less color than you think you really need. The color will look darker after the remaining finish coats are applied to the board, and excessively colored shims will end up looking like paint stripes. Do not mask off the shims—this will leave very clear borders between the tint and the bare wood. Instead spray freehand for a less conspicuous effect. Practice spraying on a piece of paper first.

In most cases *no* tinting gives the best long term result. In a few months time, the new wood will naturally darken somewhat. Besides, a well fit shim looks like a good piece of wood work, and by the time it is covered by the plate and strings it usually won't call attention to itself. Apply your choice of finish for top coats and you are done.



Routing parallel to fence



Routing cross-wise to fence



Bit extended, routing up to bridge

See all our tools and more tool instructions at our web site

[www.spurlocktools.com](http://www.spurlocktools.com)